

FIG. 1A

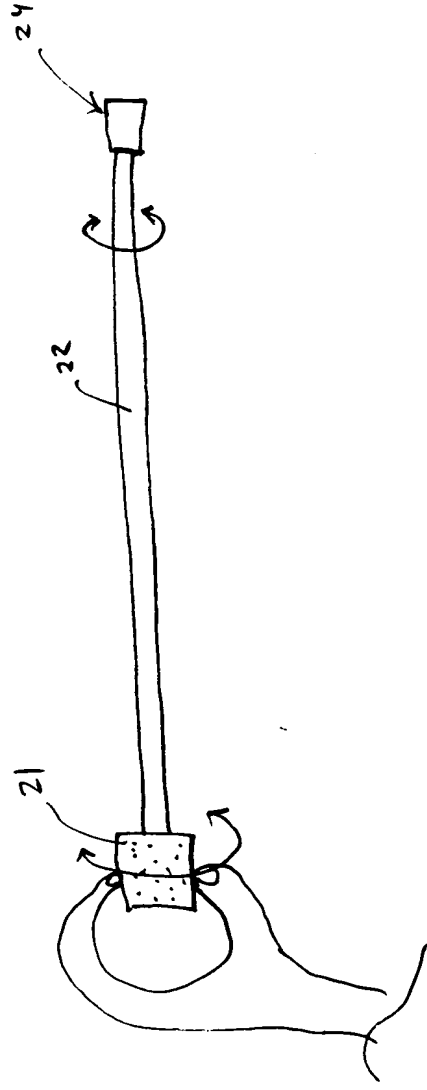

FIG. 1B

2025 RELEASE UNDER E.O. 14176

14

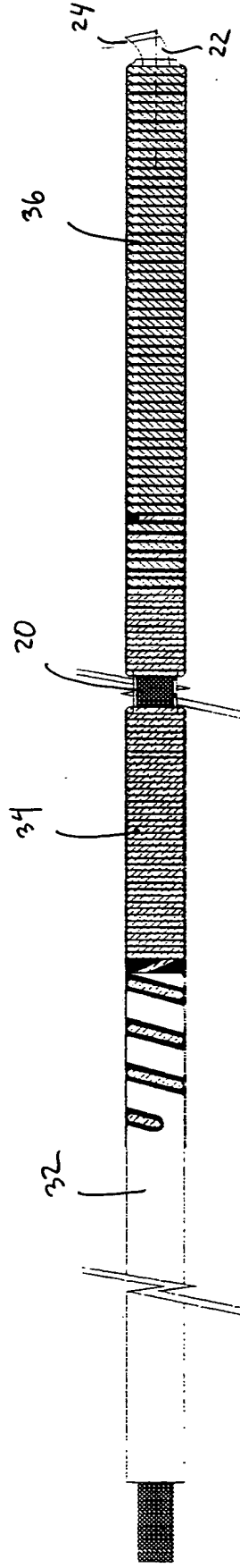

FIG. 2

2025 RELEASE UNDER E.O. 14176

10

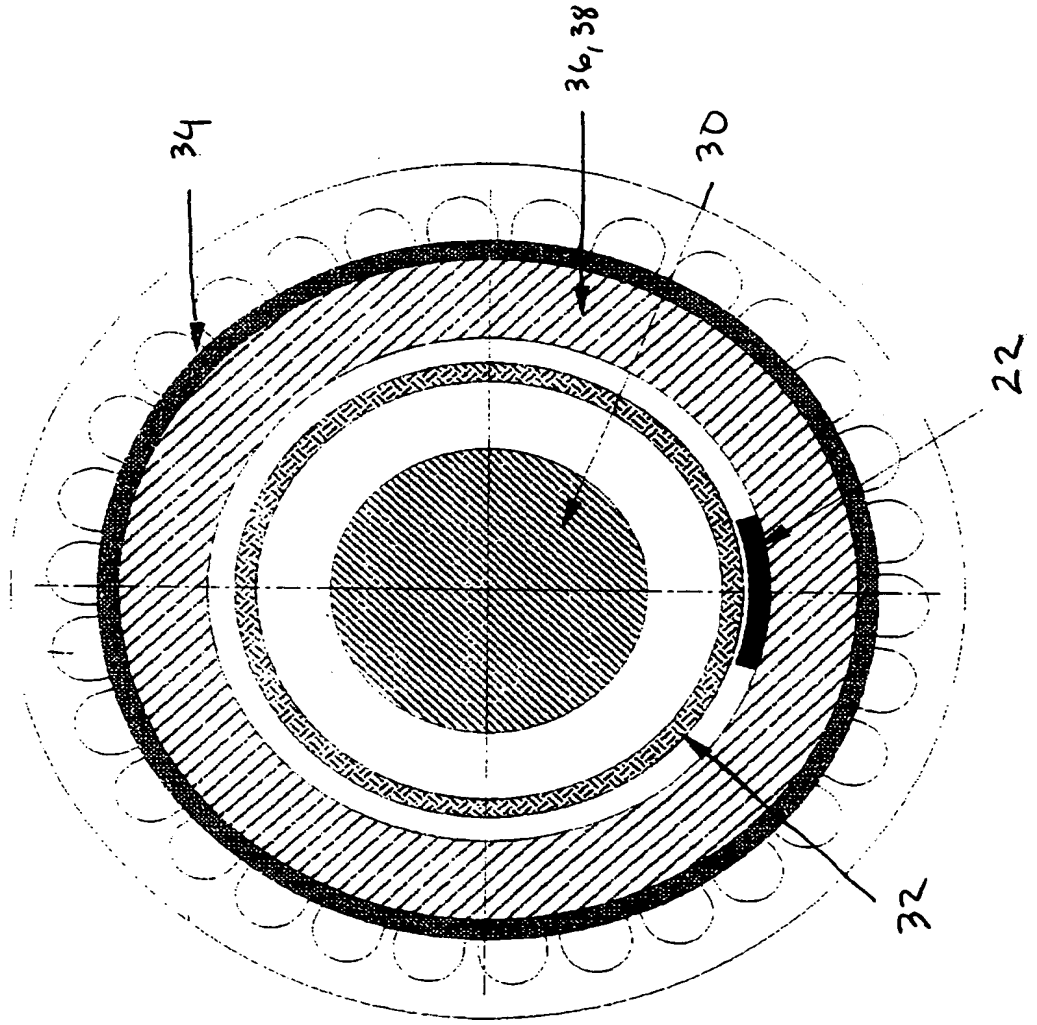

FIG. 3

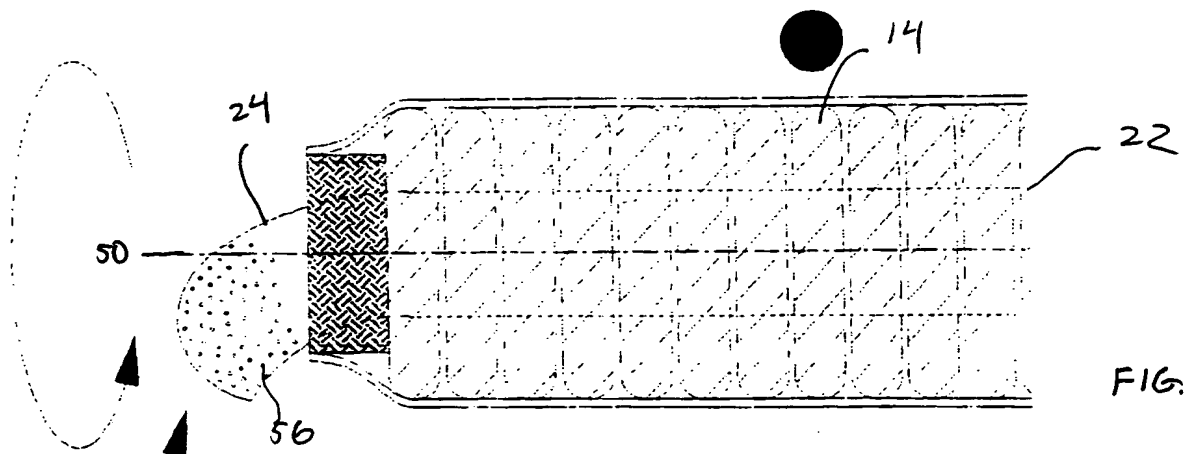

FIG. 4

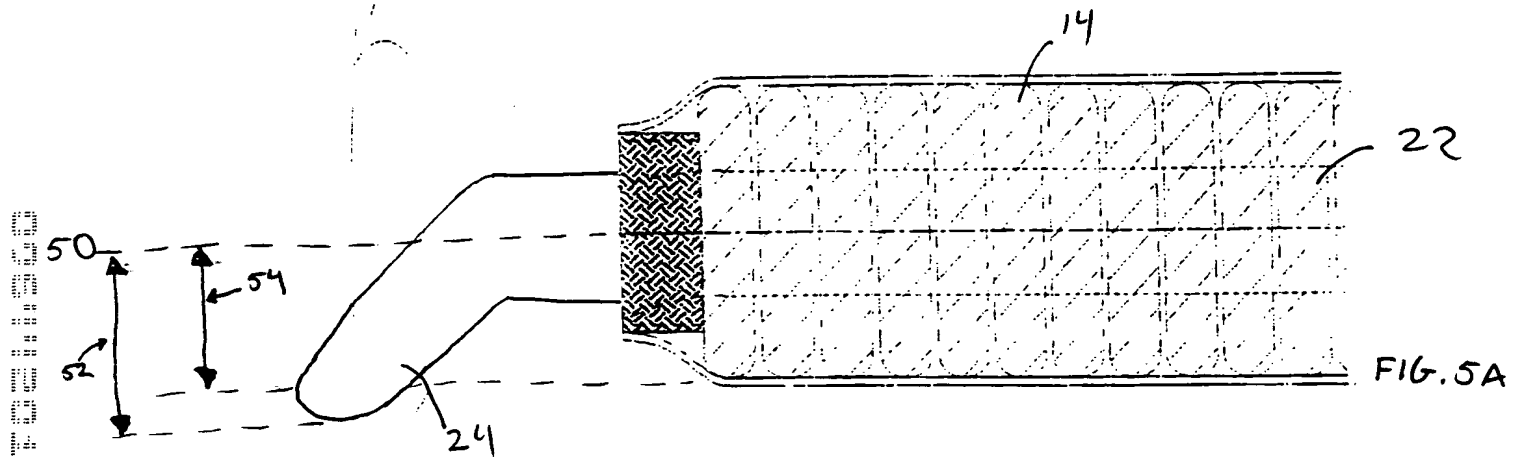

FIG. 5A

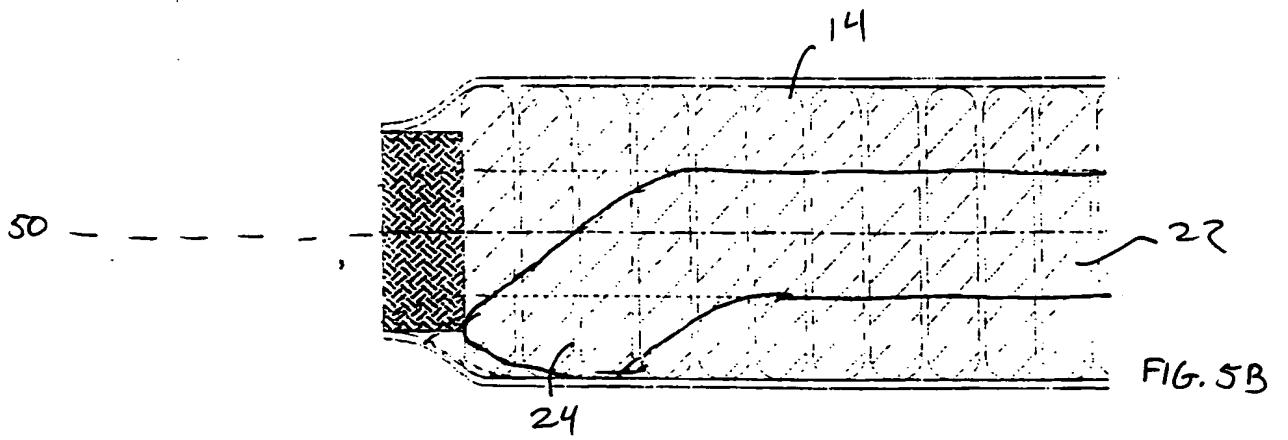

FIG. 5B

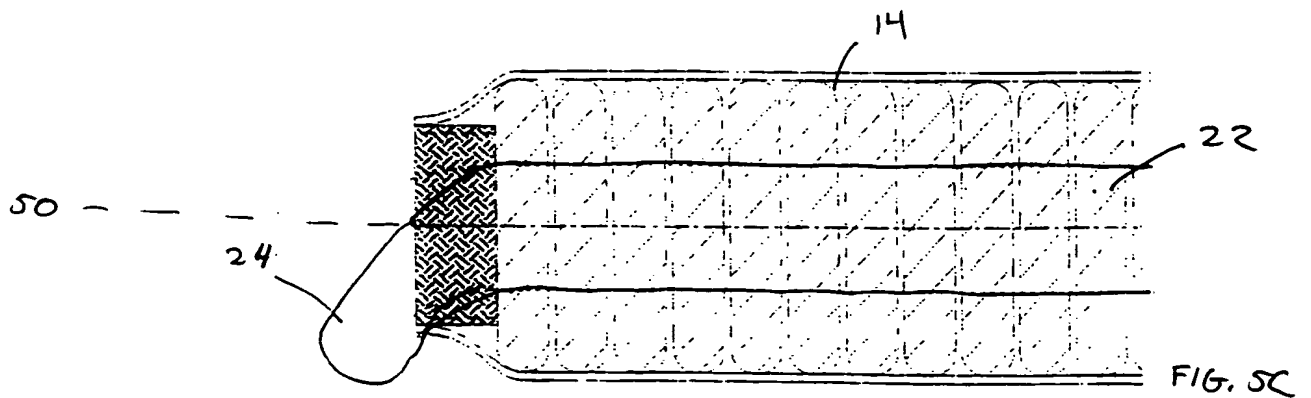
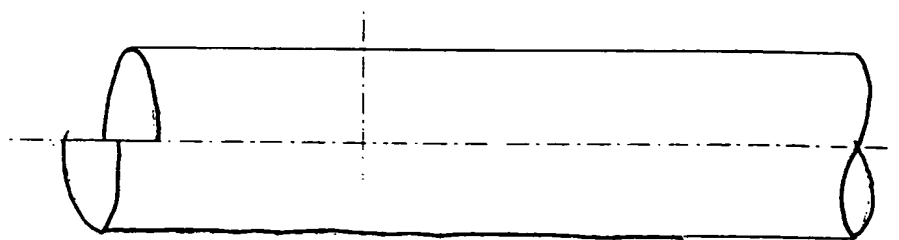
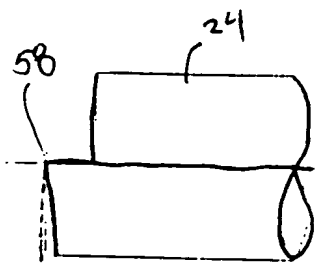
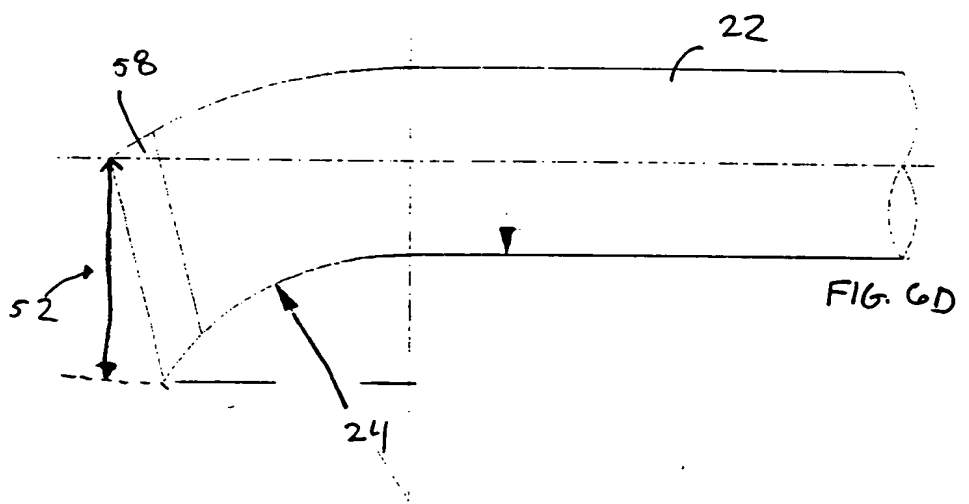
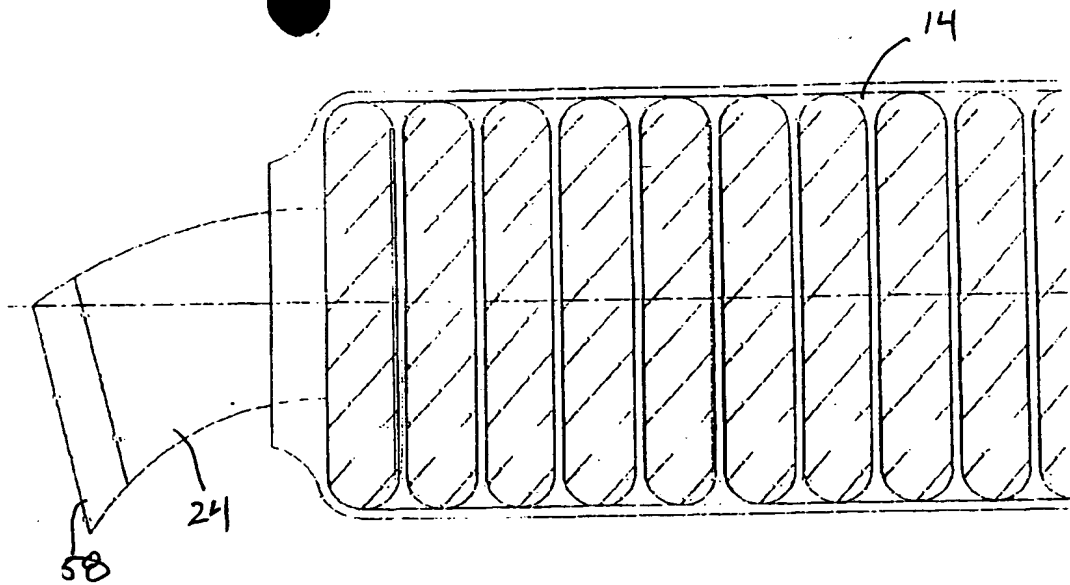

FIG. 5C

2025 RELEASE UNDER E.O. 14176



2025 RELEASE UNDER E.O. 14176

THIS DOCUMENT CONTAINS NEITHER RECOMMENDATIONS NOR
CONCLUSIONS OF THE NATIONAL BUREAU OF STANDARDS
AND IS INTENDED TO BE USED FOR INFORMATIONAL PURPOSES ONLY

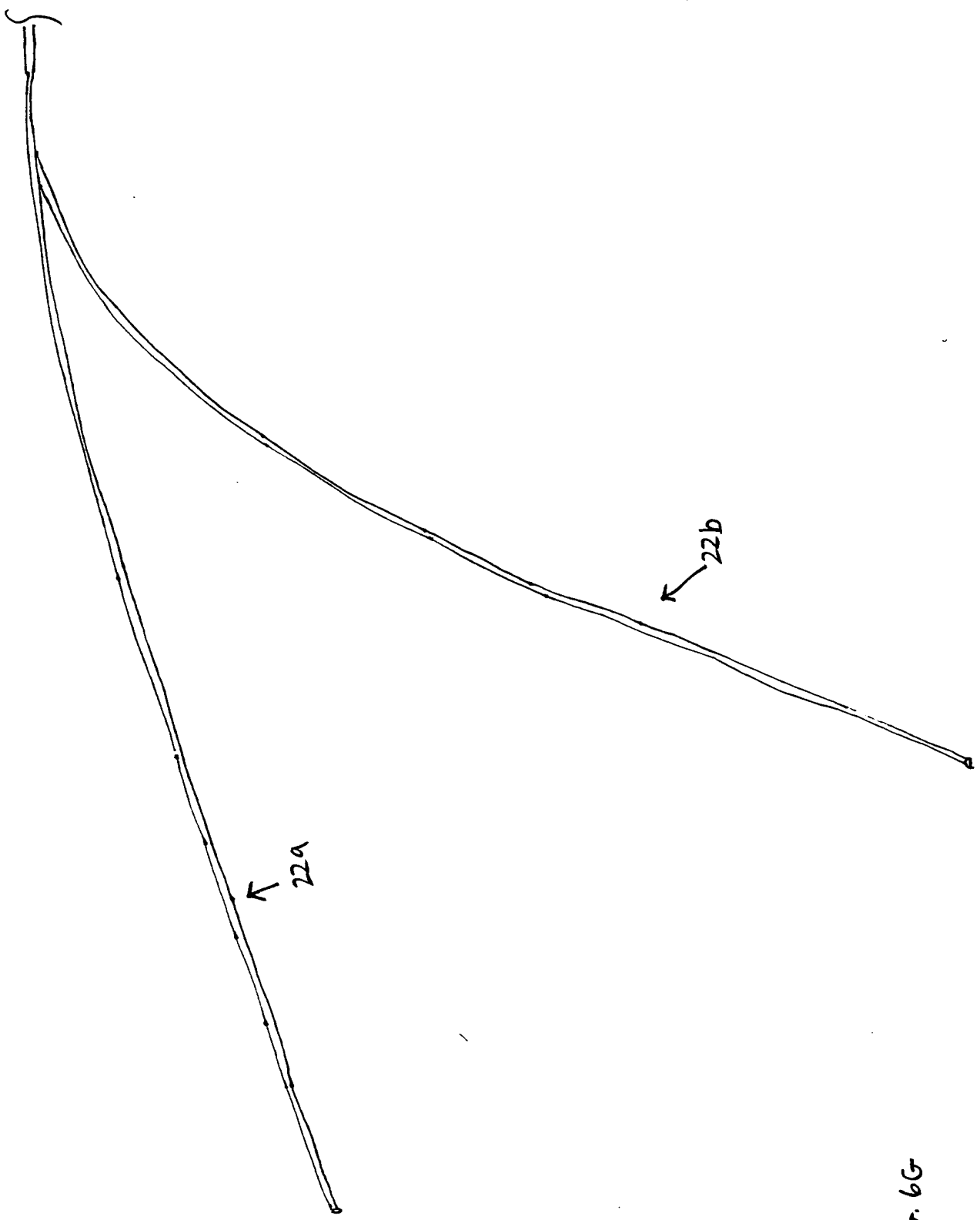

FIG. 6G

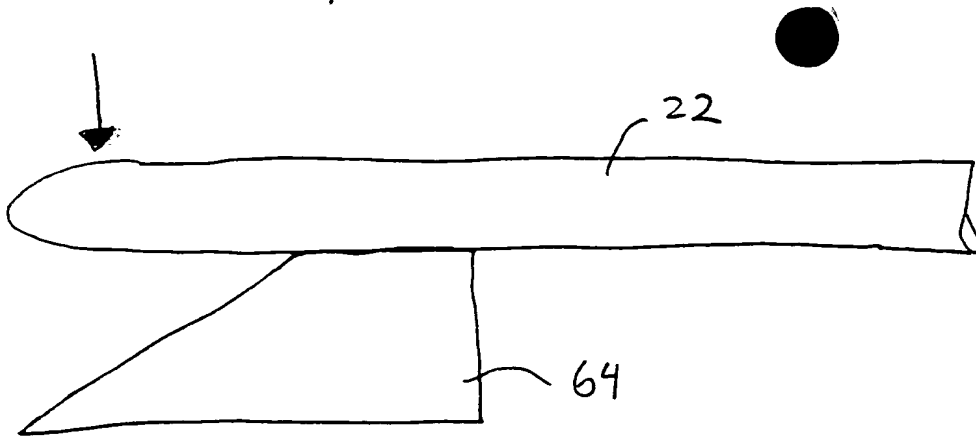

FIG. 7A

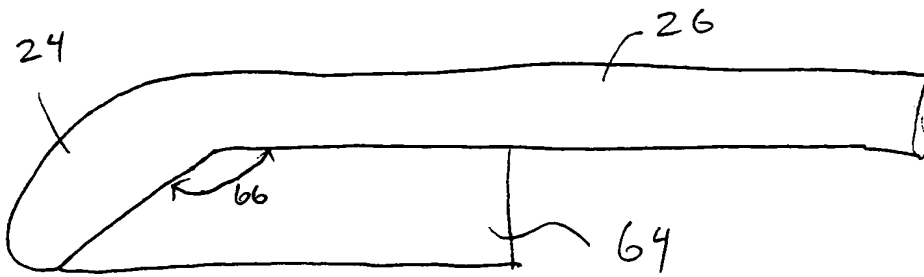

FIG. 7B

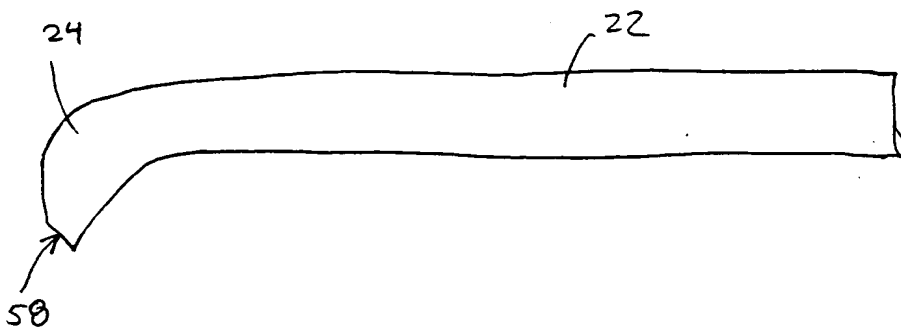

FIG. 7C

2025 RELEASE UNDER E.O. 14176

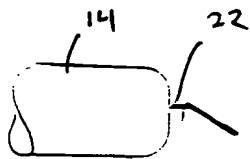

FIG. 8B

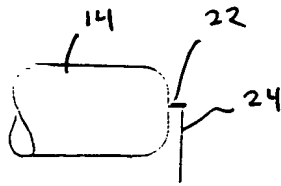

FIG. 8A

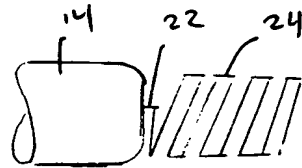

FIG. 8D

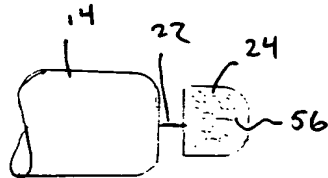

FIG. 8E

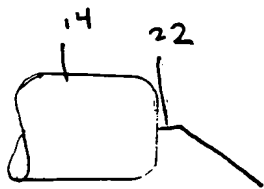

FIG. 8C

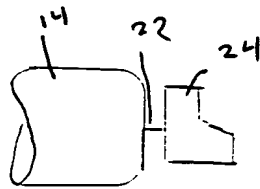

FIG. 8F

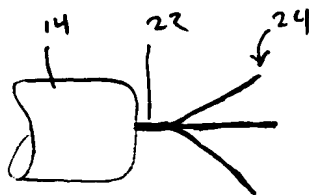

FIG. 8G

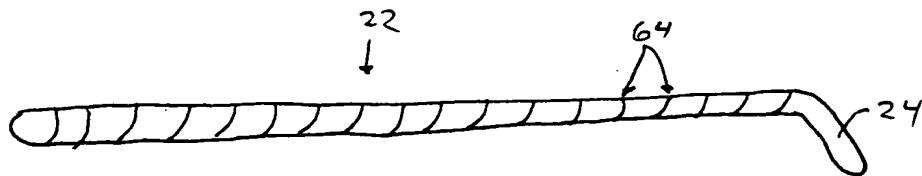

FIG. 9

2025 RELEASE UNDER E.O. 14176

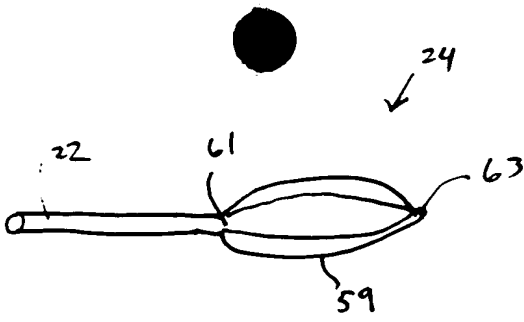

FIG. 8H

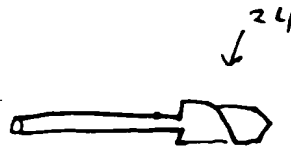

FIG. 8L

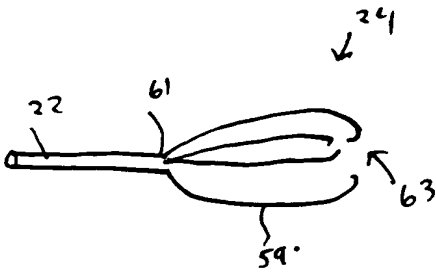

FIG. 8I

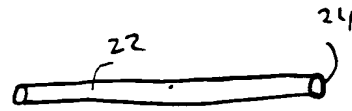

FIG. 8M

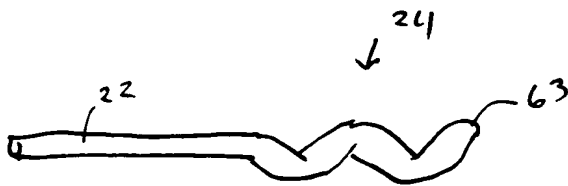

FIG. 8J

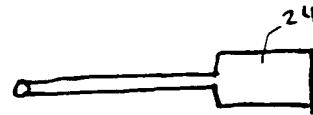

FIG. 8N



FIG. 8O

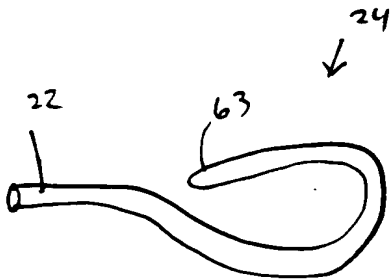

FIG. 8K



FIG. 8P

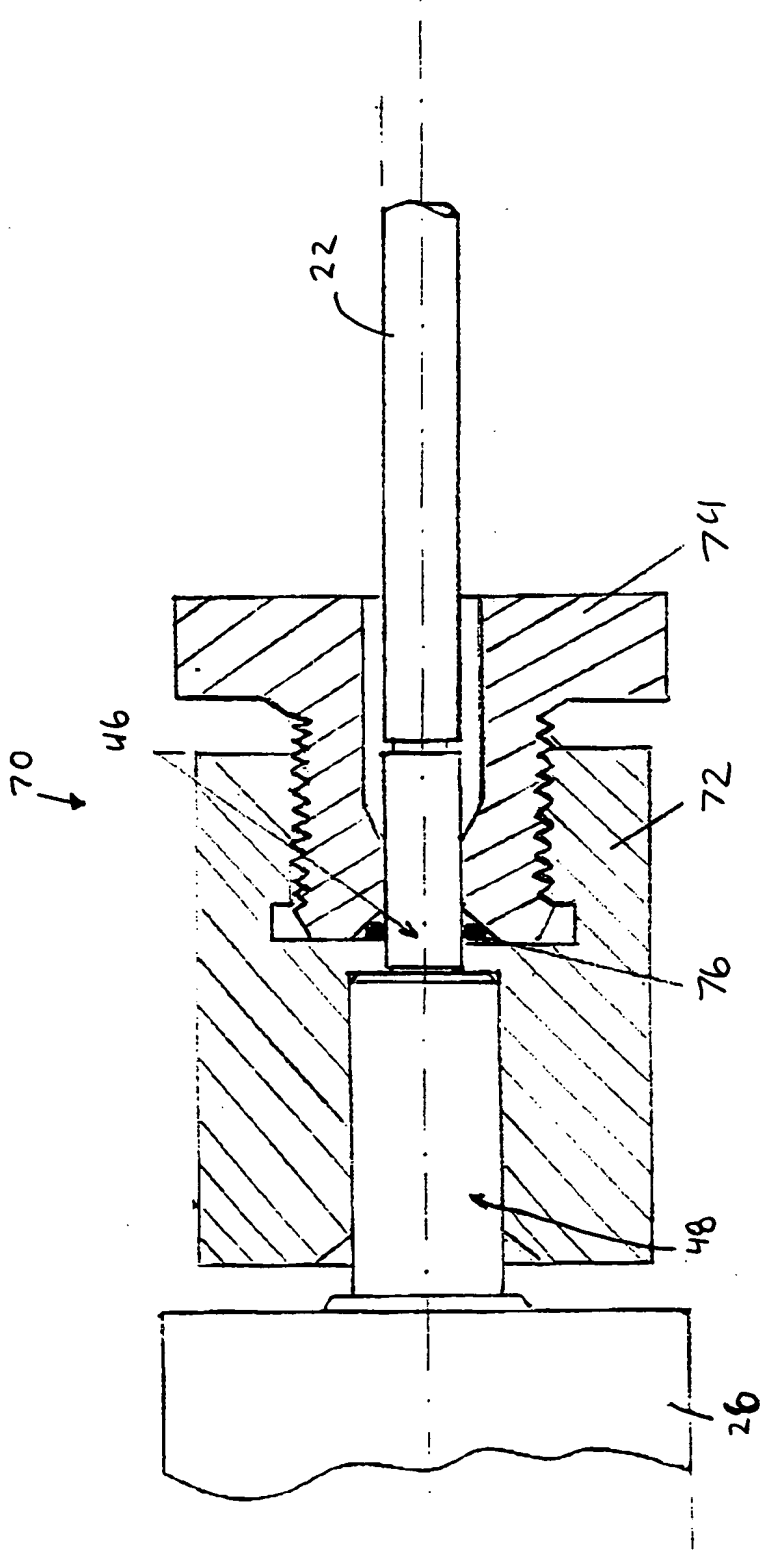

FIG. 10

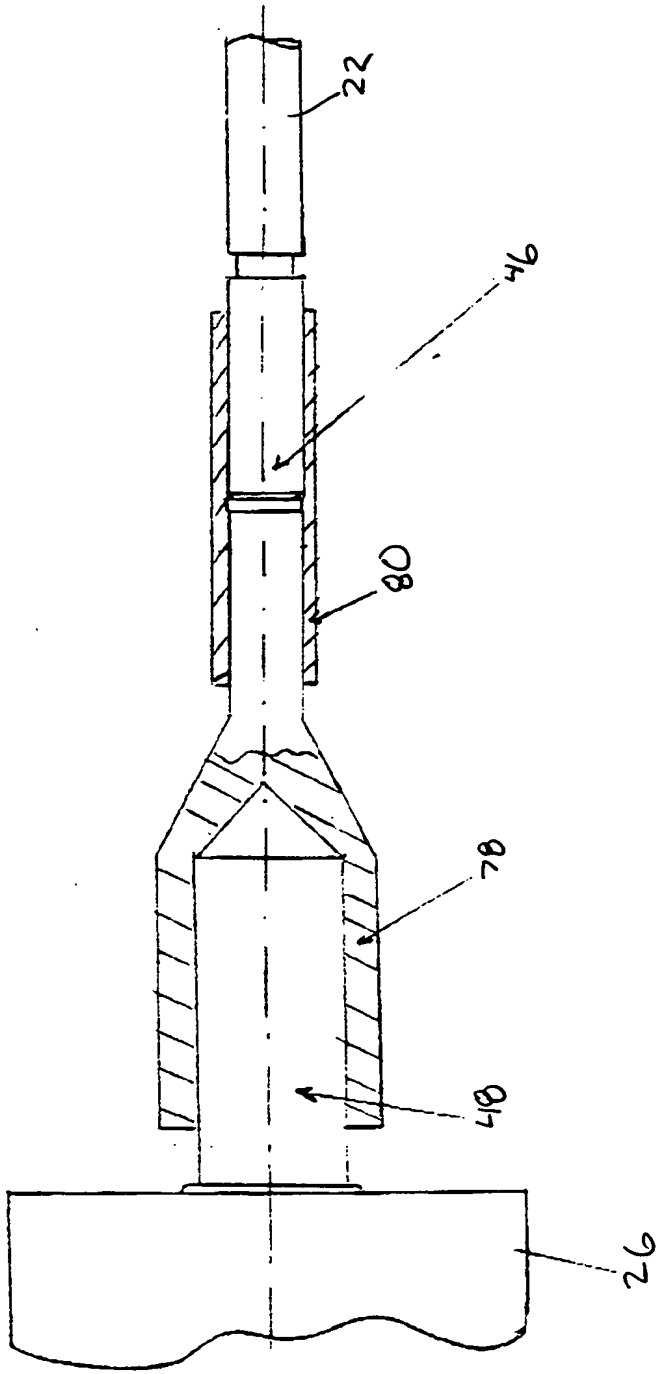

FIG. 11A

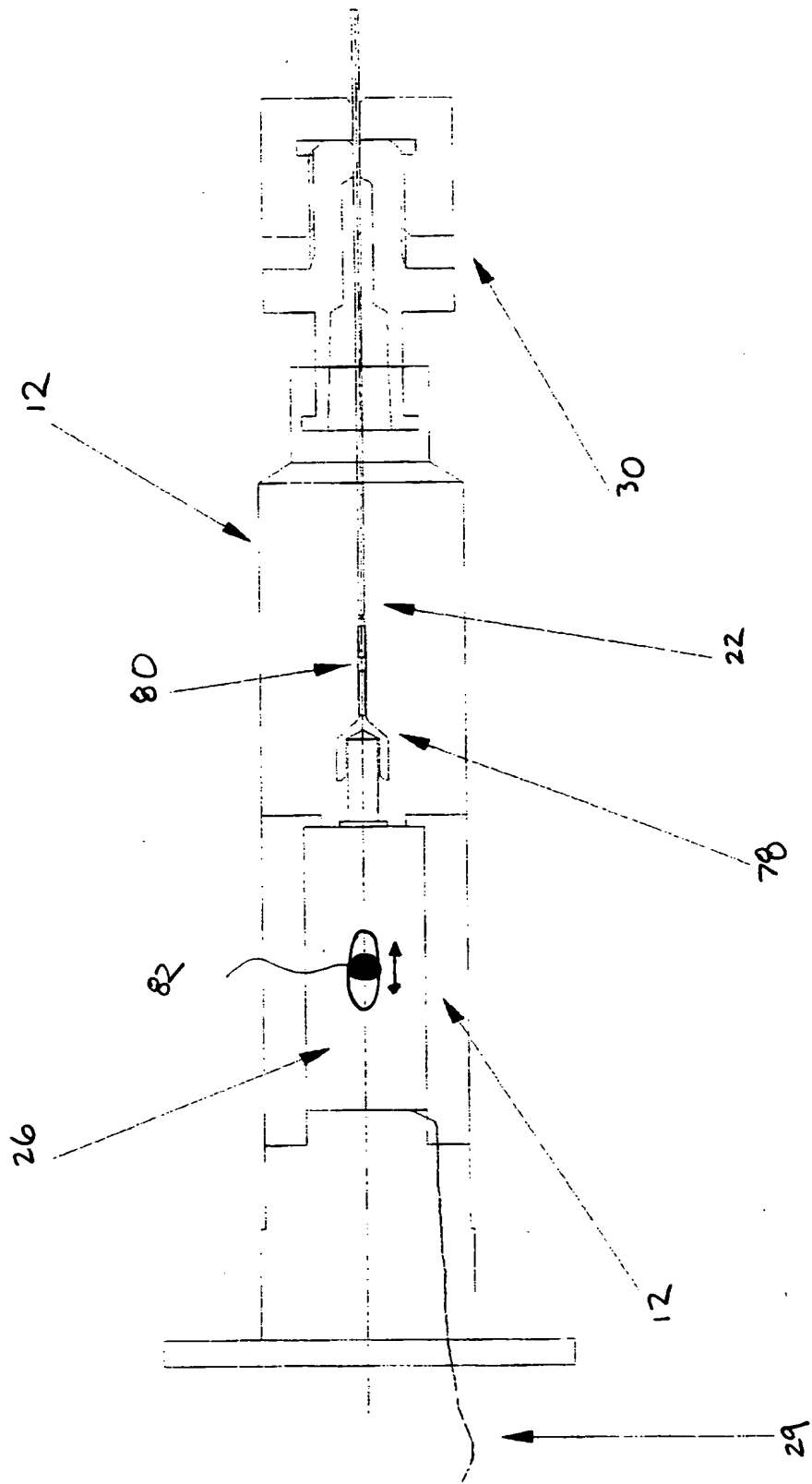

FIG. 11B

30 ←

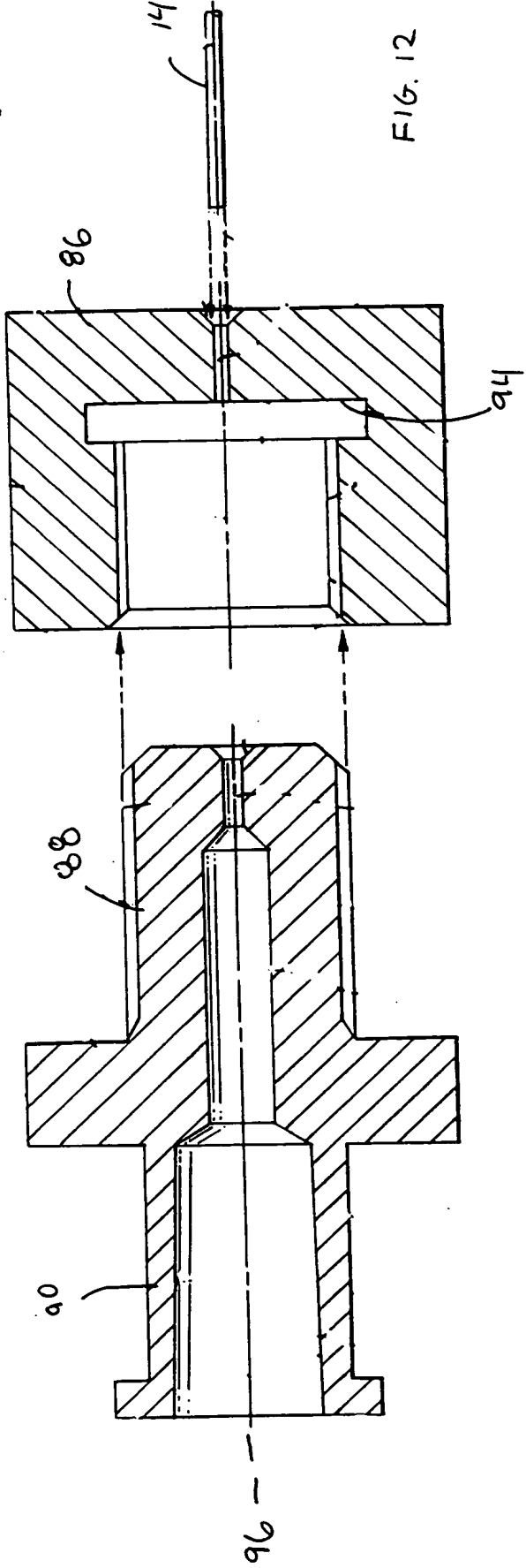

FIG. 12

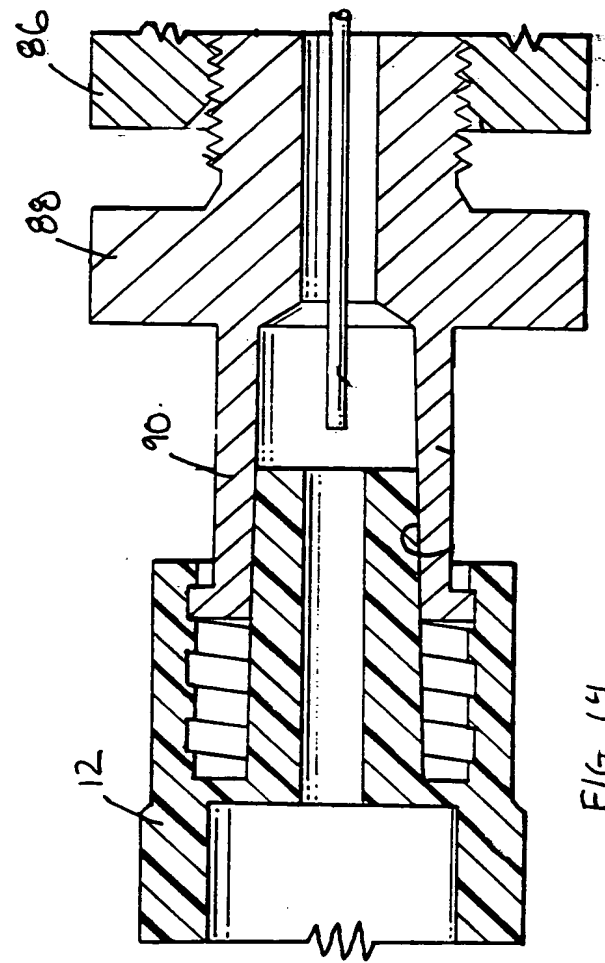

FIG. 14

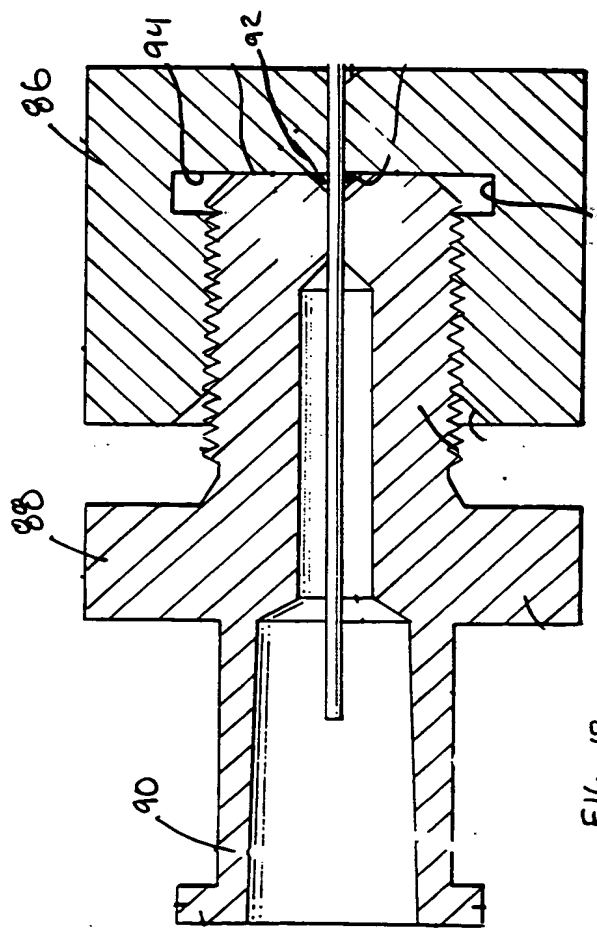

FIG. 13

2025 RELEASE UNDER E.O. 14176

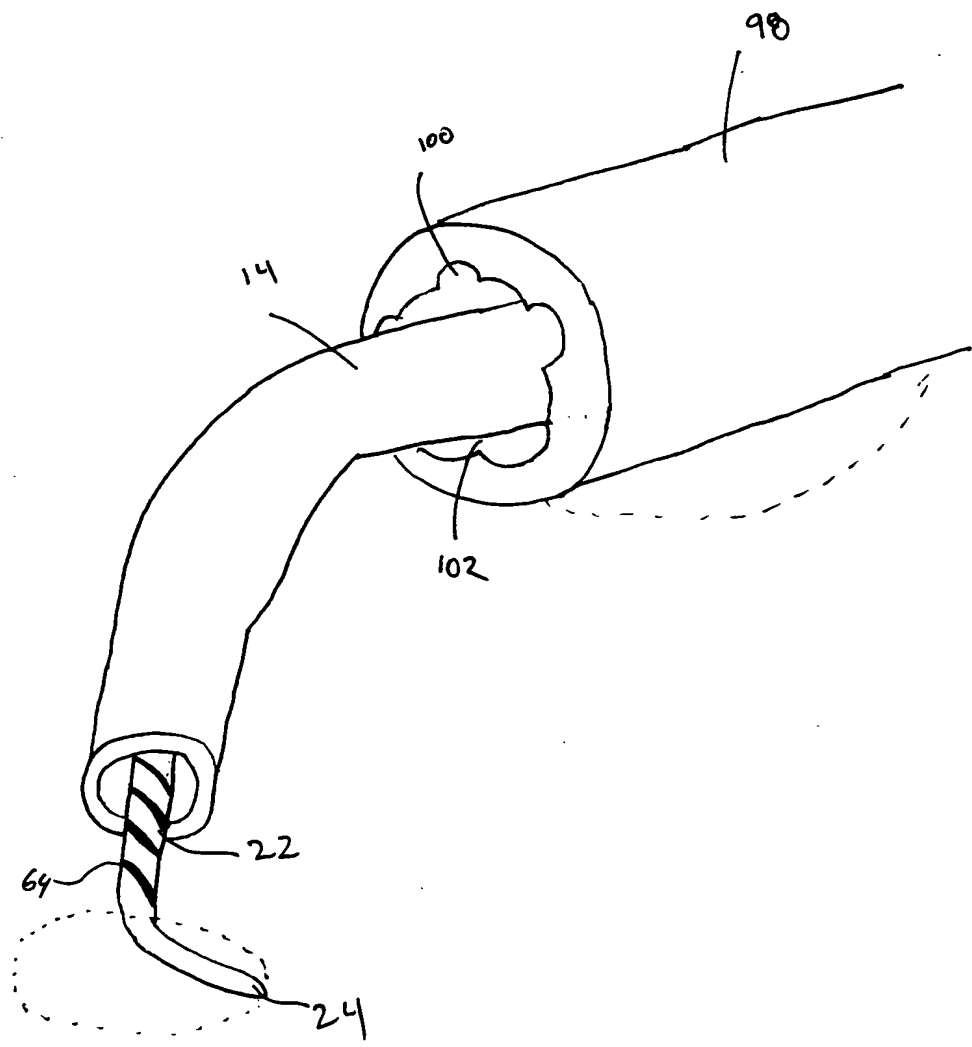
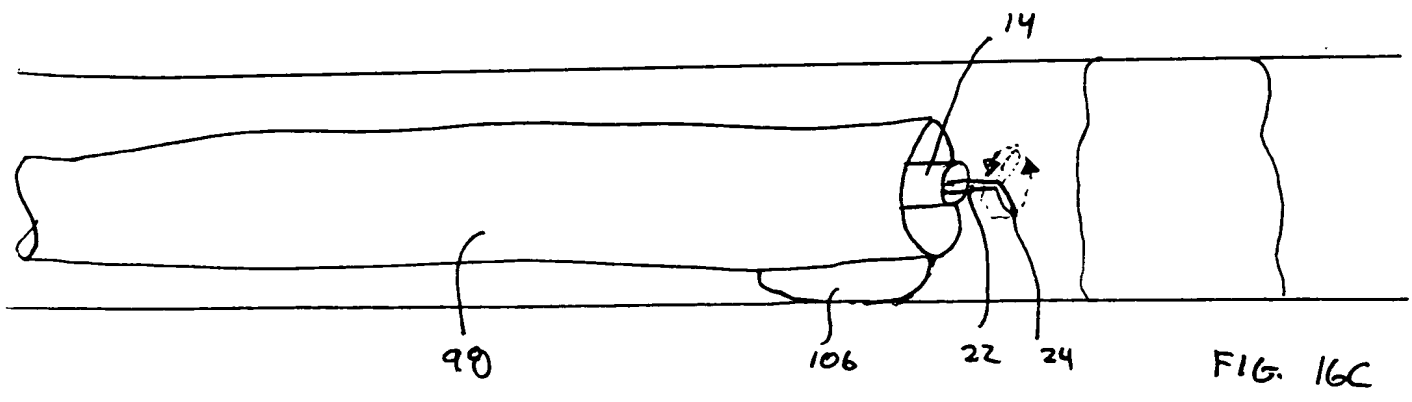
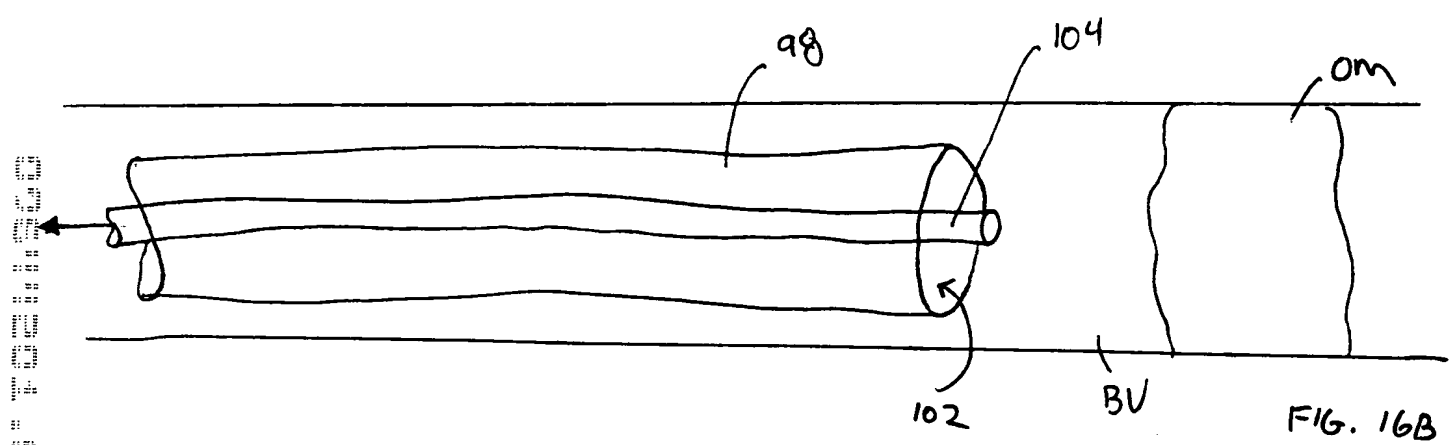
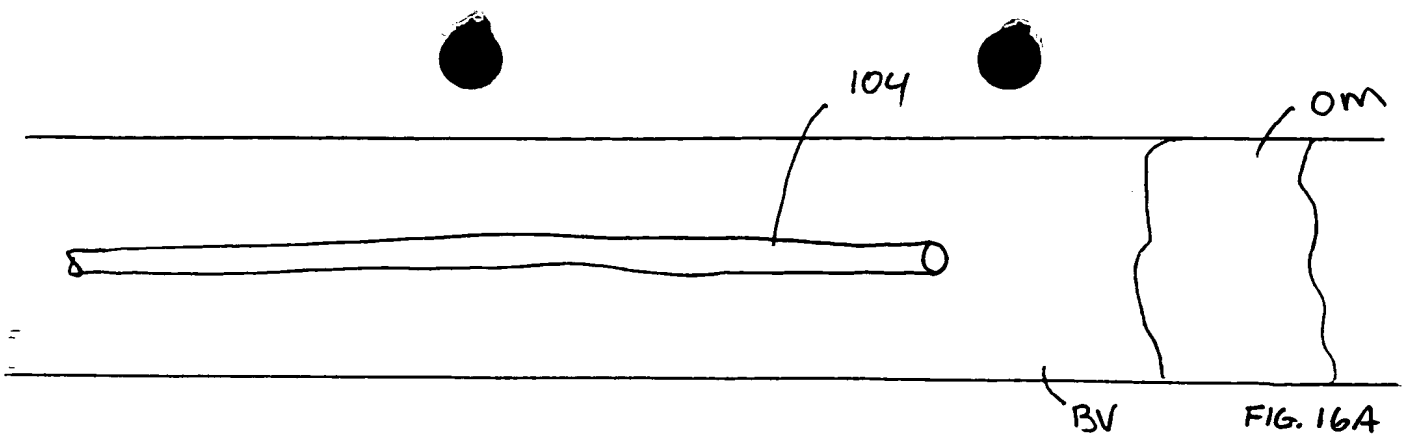

FIG. 15



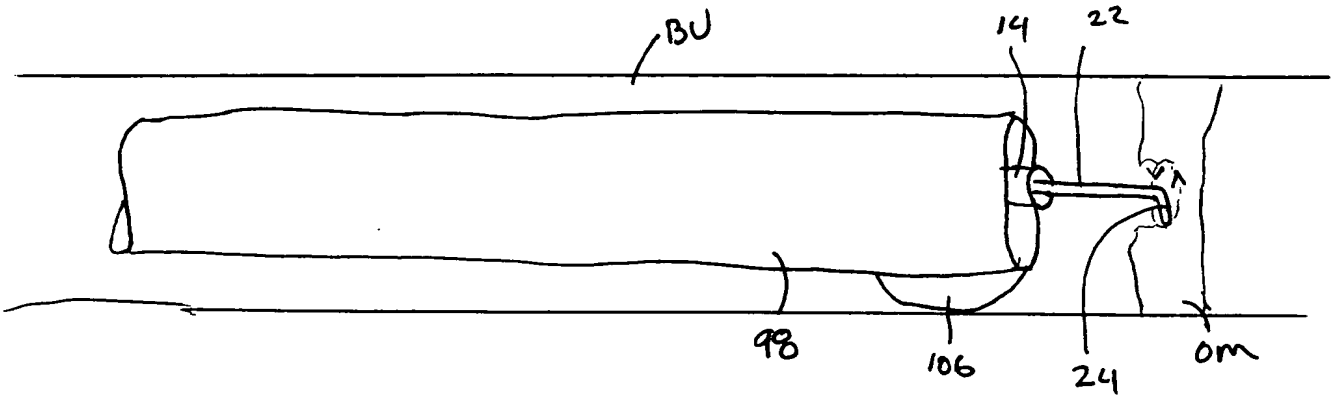

FIG. 16D

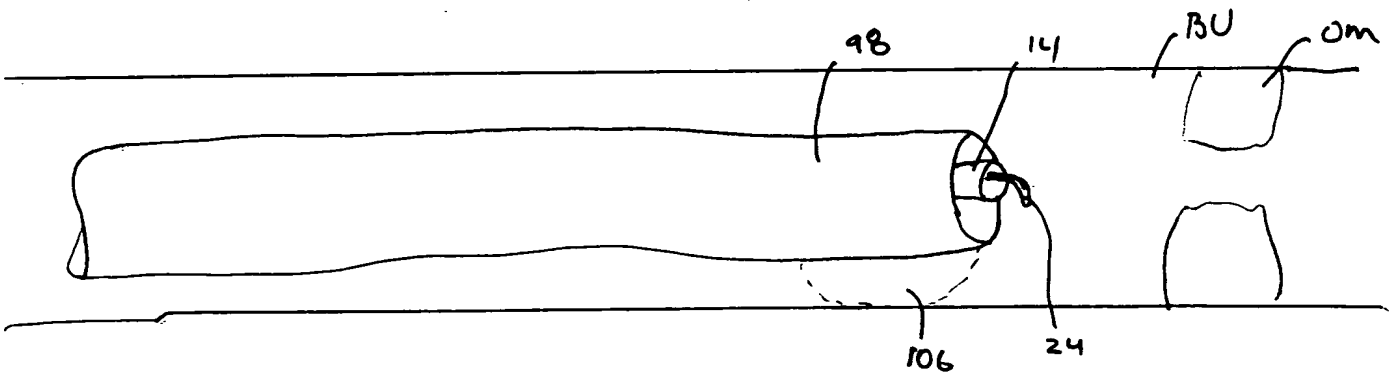

FIG. 16E

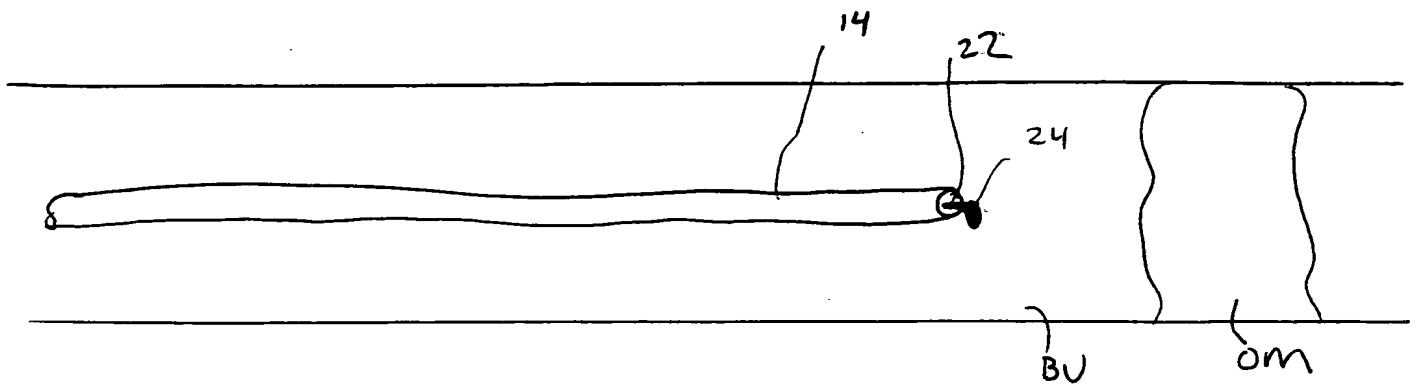

FIG. 17A

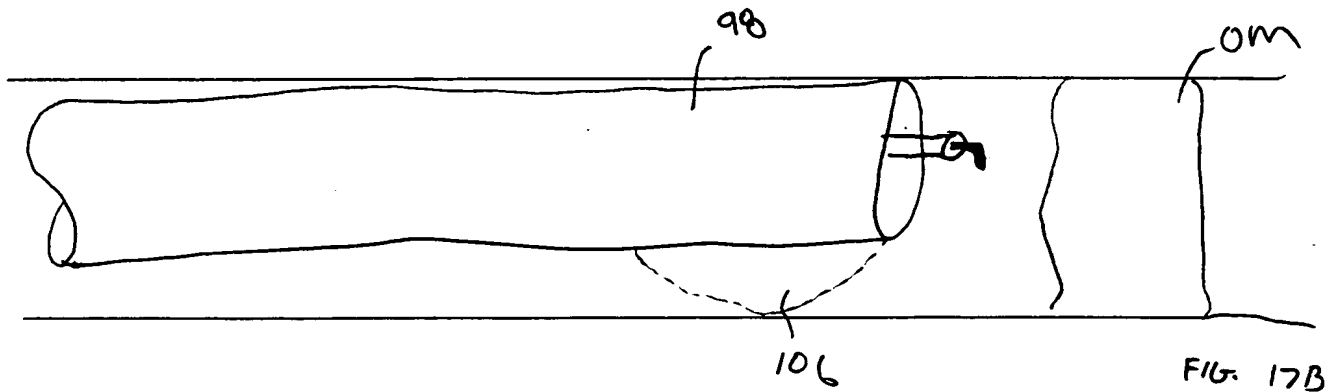

FIG. 17B

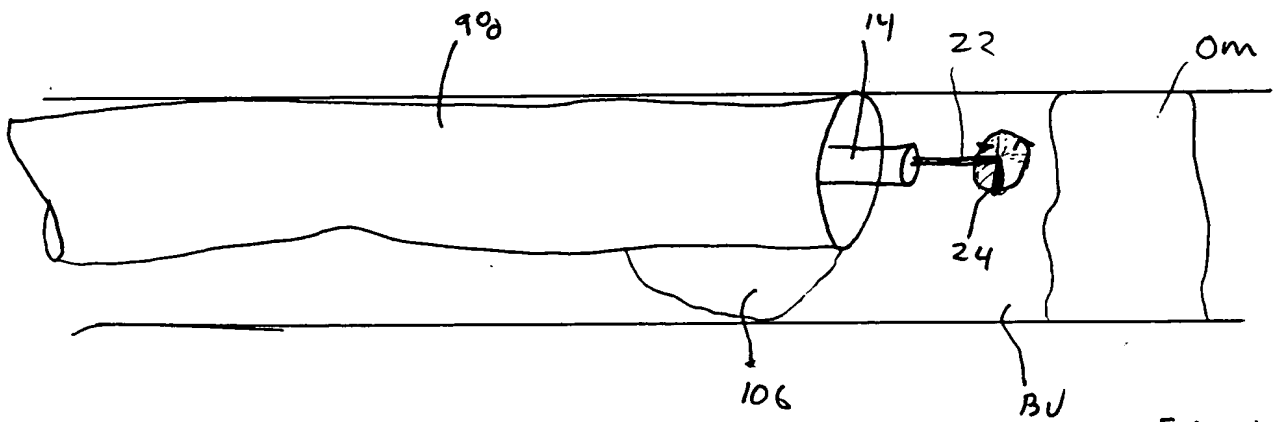

FIG. 17C

2025 RELEASE UNDER E.O. 14176

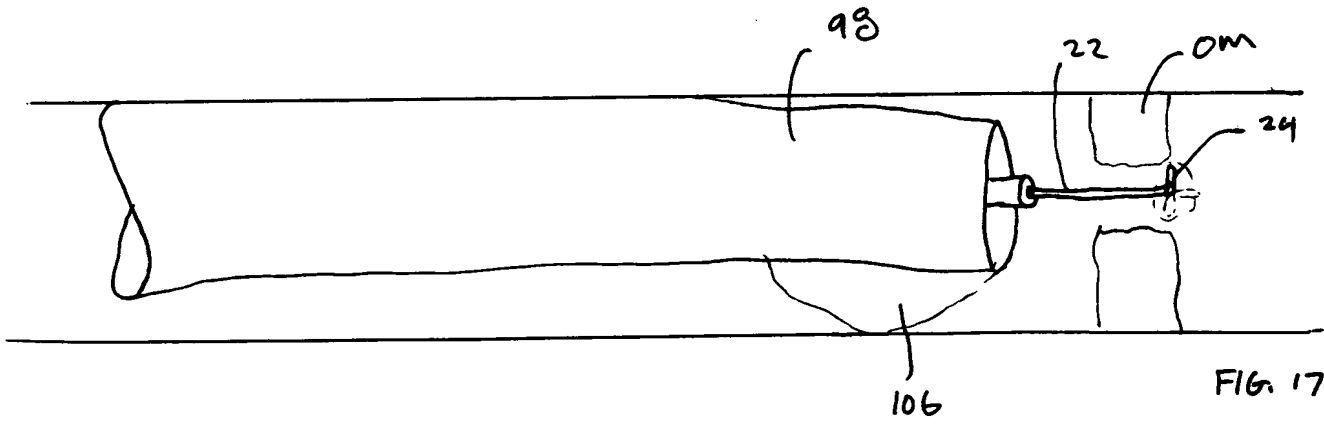

FIG. 17D

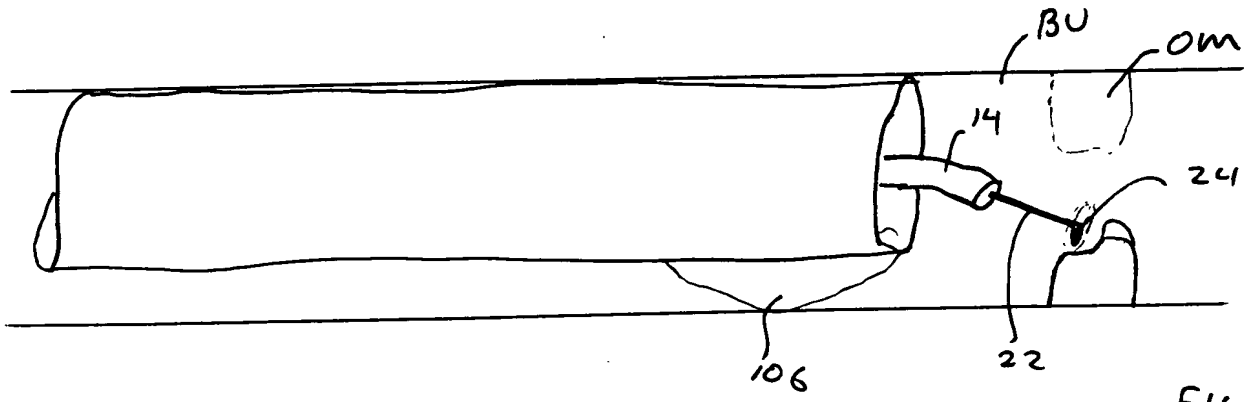

FIG. 17E

2025 RELEASE UNDER E.O. 14176

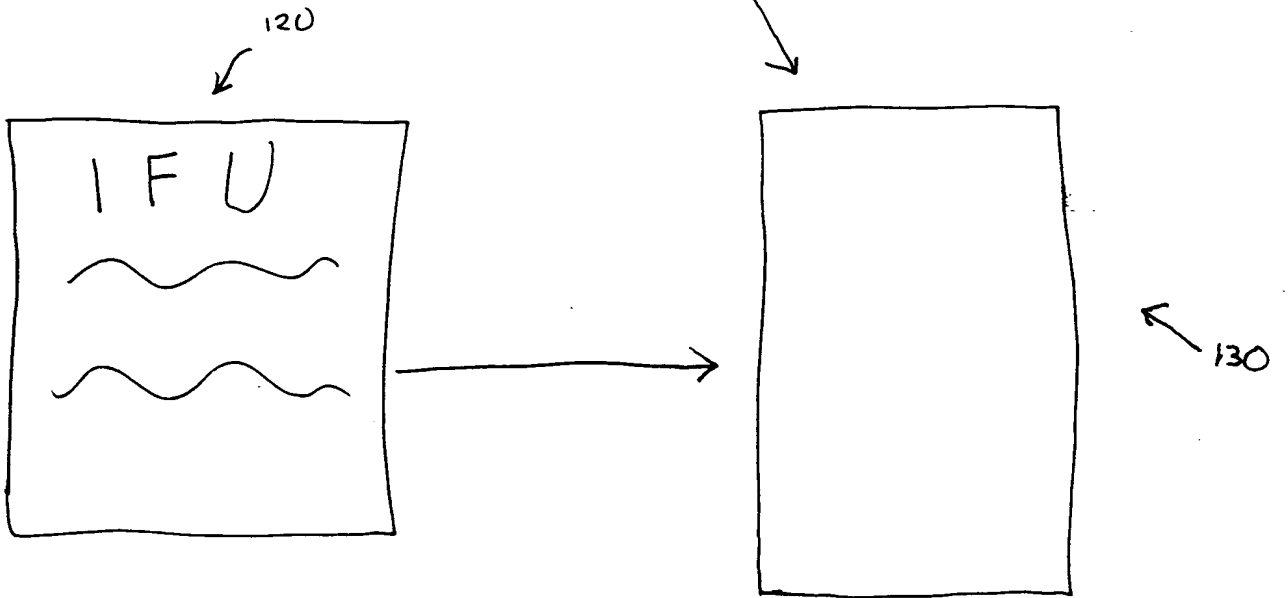
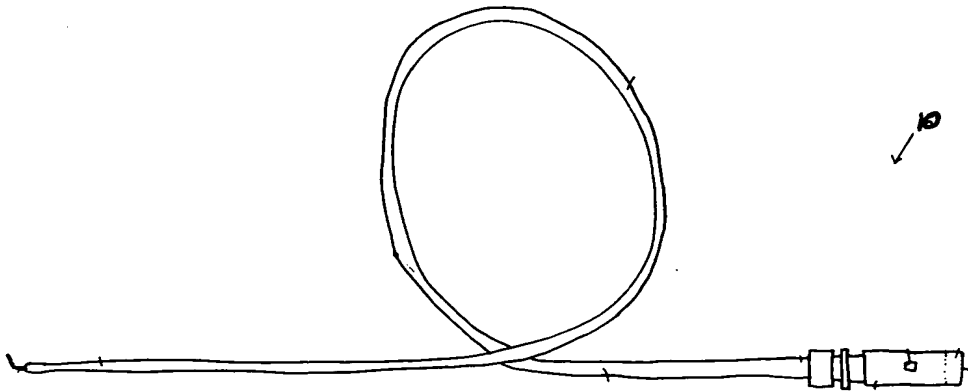

FIG. 19